

Referans Nr.	a	b	c	d	e	f	g	kg
2610-400250	500	400	250	320	200	55	50	180
2610-500300	600	500	300	400	250	75	50	240
2610-630350	700	630	350	500	315	100	50	390

Ürün Nr. 2610 Yatay İşleme Kulesi (Kare)

- Yüzeyle isteye göre uygulama.
- Malzeme GG 26 DIN normalize edilmiştir.

Product Nr. 2610 Horizontal Processing Cube (Square)

- Application on the surface according to desired way.
- Material is normalized as GG 26 DIN.

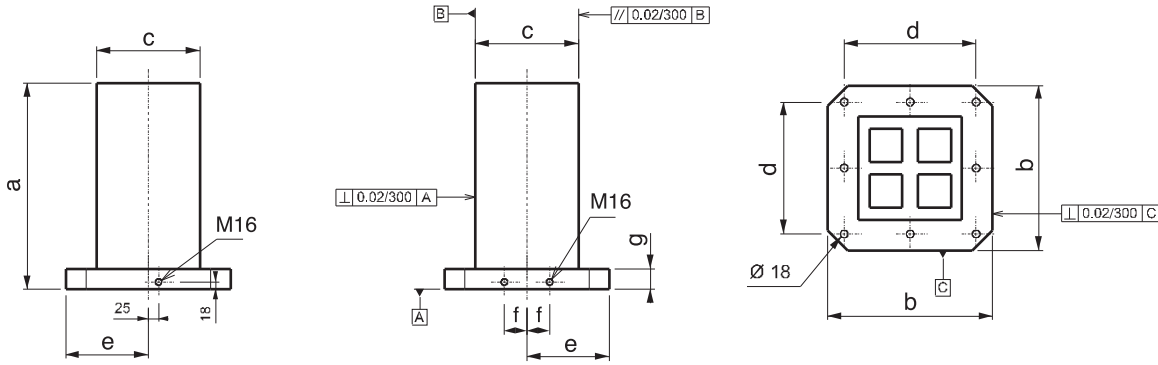

Referans Nr.	a	b	c	d	e	f	g	l	k	J ($\phi_{0.02}$)	kg
2630-40025014	500	400	250	320	200	55	50	150	100	14	165
2630-50030014	600	500	300	400	250	75	50	150	100	14	227
2630-63035014	700	630	350	500	315	100	50	150	125	14	375
2630-40025018	500	400	250	320	200	55	50	150	100	18	155
2630-50030018	600	500	300	400	250	75	50	150	100	18	223
2630-63035018	700	630	350	500	315	100	50	150	125	18	370

Ürün Nr. 2630 Yatay İşleme Kulesi (Kare) "T" Kanallı

- Dört yüzeyine iş parçası bağlanabilir.
- Standart bağlama ekipmanlarına uyumludur.
- "T" kanal ölçüsü 14mm - 18mm DIN 650 standartındadır.
- Malzeme GG 26 DIN normalize edilmiştir.

Product Nr. 2630 Horizontal Processing Cube (Square) with "T" Slot

- Workpiece can be applied on four faces.
- It is in compliance with Standard Coupling Equipment.
- "T" Slot is in the standard of 14mm - 18mm DIN 650.
- Material is normalized as GG 26 DIN.

