

MERKEZLEME BLOKLARI VE KALIP TAKVİMLERİ

KÜP BLOK KİTLEME

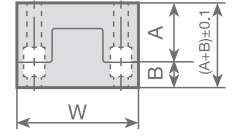
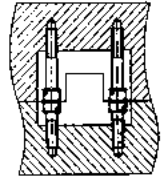
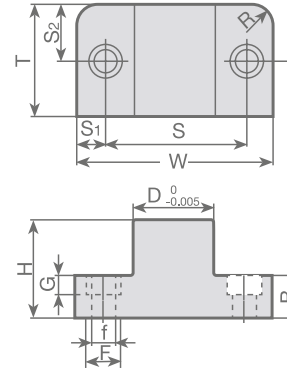
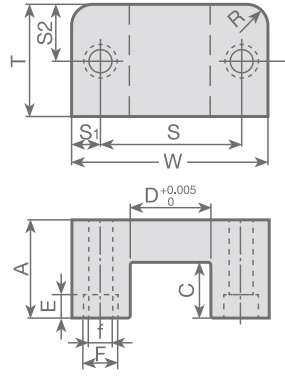

Sip. No.	W	T	A	B	C	D	E	M	F	f	G	H	R	S	S1	S2
LK 15	38.1	25.4	22.17	9.47	13.13	12.70	7	M5	10.5	6	7	22.1	7.0	25.4	6.35	12.7
LK 25	63.5	38.1	34.87	15.82	19.48	25.40	8	M6	12.0	7.2	8	34.8	8.5	44.45	9.53	19.05
LK 35	88.9	50.8	44.4	19.0	25.70	36.58	11	M8	15.5	10.5	11	44.2	9.5	63.5	12.7	25.4

KARE BLOK KİTLEME

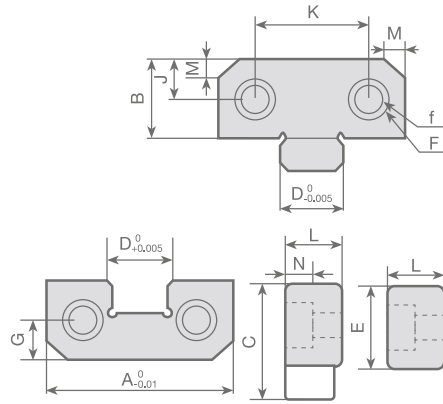

Sip. No.	A	B	C	D	E	F	f	G	J	K	L	M	N
PL 38	38	22	30	12	17	10.5	6.5	7	11	22	13	5	8
PL 50	50	21.5	30	17	21.5	10.5	6.5	11	11	34	16	5	8
PL 75	75	36	50	25	36	16.5	10.5	18	18	50	19	8	12
PL 100	100	45	65	35	45	16.5	10.5	22	22	70	19	10	12
PL 125	125	45	65	45	45	16.5	10.5	22	22	84	25	10	12

UZUN KARE KİTLEME

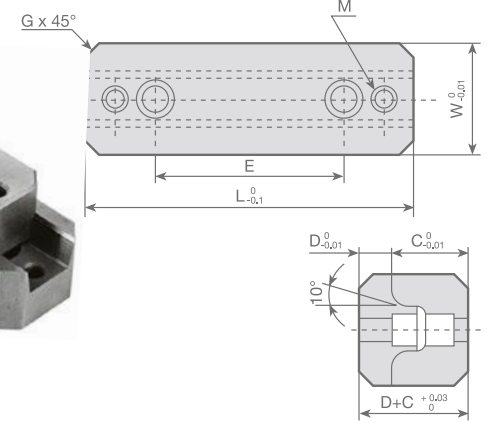

Sip. No.	L	w	C	D	E	G	M
KYSO	50	25	17.5	8	36	5	M5
KY100	100	30	22	10	60	5	M6
KY150	150	40	25	13	100	5	M6

KALIP TAKVİMLERİ

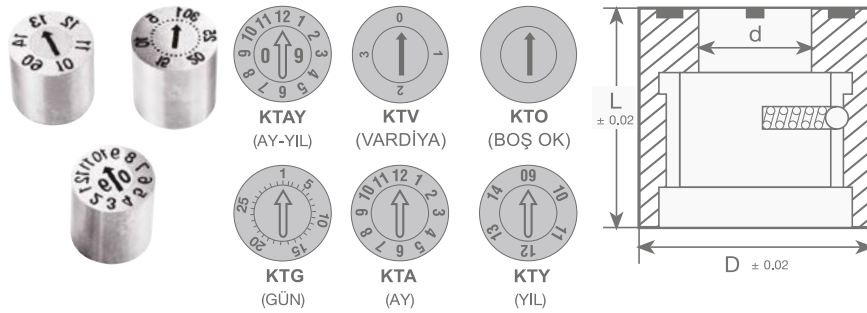

YIL KALIP TAKVİMİ

Sip. No.	D(mm)	L	d	Sip. No.	D(mm)	L	d
KTY4	4	6	2.2	KTY10	10	10	4.7
KTY5	5	8	2.5	KTY12	12	12	6
KTY6	6	8	3	KTY16	16	12	7
KTY8	8	8	4	KTY20	20	14	10

VARDİYA KALIP TAKVİMİ

Sip. No.	D(mm)	L	d	Sip. No.	D(mm)	L	d
KTV4	4	6	2.2	KTV10	10	10	4.7
KTV5	5	8	2.5	KTV12	12	12	6
KTV6	6	8	3	KTV16	16	12	7
KTV8	8	8	4	KTV20	20	14	10

AY YIL KALIP TAKVİMİ

Sip. No.	D(mm)	L	d	Sip. No.	D(mm)	L	d
KTAY4	4	6	2.2	KTAY10	10	10	4.7
KTAY5	5	8	2.5	KTAY12	12	12	6
KTAY6	6	8	3	KTAY16	16	12	7
KTAY8	8	8	4	KTAY20	20	14	10

GÜN KALIP TAKVİMİ

Sip. No.	D(mm)	L	d	Sip. No.	D(mm)	L	d
KTG4	4	6	2.2	KTG10	10	10	4.7
KTG5	5	8	2.5	KTG12	12	12	6
KTG6	6	8	3	KTG16	16	12	7
KTG8	8	8	4	KTG20	20	14	10

AY KALIP TAKVİMİ

Sip. No.	D(mm)	L	d	Sip. No.	D(mm)	L	d
KTA4	4	6	2.2	KTA10	10	10	4.7
KTA5	5	8	2.5	KTA12	12	12	6
KTA6	6	8	3	KTA16	16	12	7
KTA8	8	8	4	KTA20	20	14	10