

## AÇILI PİM TUTUCU 10°-15° (GR)

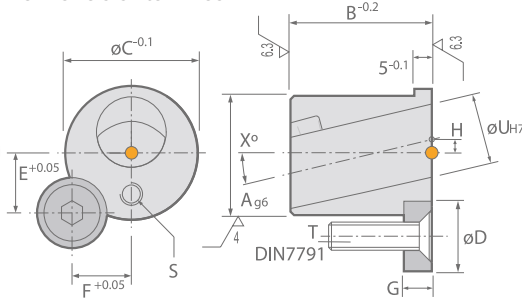

- Malzeme : 1.7242
- Bu ünite kalıp üzerinde açılı delik delme ihtiyacını ortadan kaldırır.
- Üniteyi oturtmak için kalıbın ön tarafından bir delik delinir.
- 10°-15° olarak temin edilir.



Sip. No.	A	B	C	D	E	F	G	H	s	T	u	x°
GR.182622-10	18	26	22	12	10.8	7.5	6	3.8	M5x5	M5x16	10	10
GR.222826-10	22	28	26	16	11	11	6	4	M6x6	M6x16	12	10
GR.283432-10	28	34	32	16	13	13	6	5	M6x6	M6x16	16	10
GR.344038-10	34	40	38	20	17	17	8	5.5	M8x6	M8x20	20	10
GR.424546-10	42	45	46	20	19.5	19.5	8	6	M8x6	M8x20	24	10
GR.465050-10	46	50	50	20	21	21	8	7	M8x6	M8x20	28	10
GR.182622-15	18	26	22	12	10.8	7.5	6	3.8	MSxS	M5x16	10	15
GR.222826-15	22	28	26	16	11	11	6	4	M6x6	M6x16	12	15
GR.283432-15	28	34	32	16	13	13	6	5	M6x6	M6x16	16	15
GR.344038-15	34	40	38	20	17	17	8	5.5	M8x6	M8x20	20	15
GR.424546-15	42	45	46	20	19.5	19.5	8	6	M8x6	M8x20	24	15
GR.465050-15	46	so	so	20	21	21	8	7	M8x6	M8x20	28	15