

ESNEK İÇ MAÇA (PW)

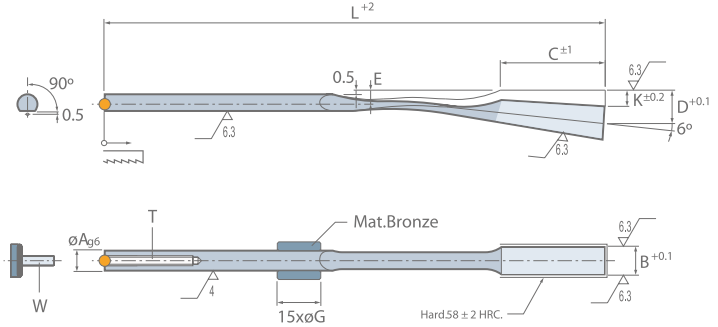

- Esnek İç Maça : Yay çeliğinden imal edilmiştir. küçük tırnakların çıkarılmasında kullanılır. Diğer iticiler gibi itici plakasıyla birlikte çalışır
- Malzeme : 8159 Templado 45 ± 3 HRC



Sip. No.	A	B	C	D	E	G	K	L	M	N	R	T	U	V	W	CS
PW.060622	6	6.2	22	9	3.5	-	3.5	125	16	18	1.25	M4x36	12	5	M4x16(DIN7991)	-
PW.060630	6	6.2	30	10	3.5	12	4.5	175	20	26	1.25	M4x36	12	5	M4x16(DIN7991)	•
PW.060822	6	8.2	22	9	3.5	-	3.5	125	16	18	1.25	M4x36	12	5	M4x16(DIN7991)	-
PW.060830	6	8.2	30	10	3.5	12	4.5	175	20	26	1.25	M4x36	12	5	M4x16(DIN7991)	•
PW.080825	8	8.2	25	11.5	4.5	-	4.5	140	18	21	2	M5x36	14	6	M5x16(DIN7984)	-
PW.081025	8	10.2	25	11.5	4.5	-	4.5	140	18	21	2	M5x36	14	6	M5x16(DIN7984)	-
PW.081030	8	10.2	30	11.2	4.5	12	4.5	175	20	26	2	M5x36	14	6	M5x16(DIN7984)	•
PW.081225	8	12.2	25	11.5	4.5	-	4.5	140	18	21	2	M5x36	14	6	M5x16(DIN7984)	-
PW.081230	8	12.2	30	11.2	4.5	12	4.5	175	20	26	2	M5x36	14	6	M5x16(DIN7984)	•
PW.101430	10	14.2	30	13.6	5.5	16	5.5	175	20	26	2.5	M6x36	18	8	M6x16(DIN7984)	•
PW.101630	10	16.2	30	13.6	5.5	16	5.5	175	20	26	2.5	M6x36	18	8	M6x16(DIN7984)	•
PW.101830	10	18.2	30	13.6	5.5	16	5.5	175	20	26	2.5	M6x36	18	8	M6x16(DIN7984)	•

