

TCMT 11/16 COUNTERSINK END MILLS

TCMT 11/16 / ISO

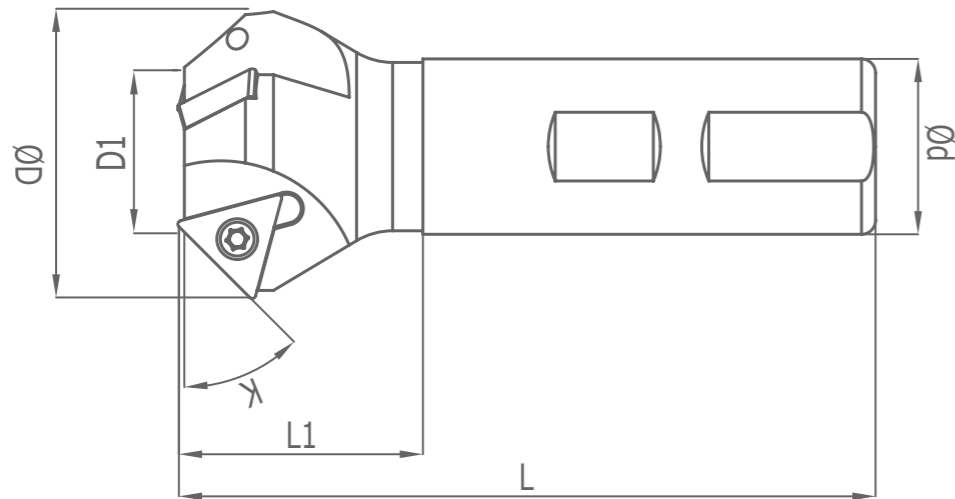

4
ISO



ISO TCMT 11/16	Stock	K	D	D1	d	L	L1	Insert	Screw	Torx Key
1138700	•	45°	15	4	16	L100	35	TC..11	M2,5X7	T8
1138800	•	45°	25	14	25	L100	35			
1138900	•	45°	30	16	12	L100	35			
1139000	•	45°	35	21	12	L100	35			
1139100	•	45°	23	5	16	L100	35	TC..16	M3,5X8	T15
1139200	•	45°	31	10	16	L100	35			
1139300	•	45°	35	14	20	L100	35			
1139400	•	45°	70	25	25	L100	35			
1139500	•	45°	43	22	25	L100	35			
1139600	•	45°	50	30	25	L100	35			
1139700	•	45°	64	35	32	L100	35	TC..22	M5X12	T20
1139800	•	60°	20	6	16	L100	35	TC..16	M3,5X8	T15
1139900	•	60°	35	20	16	L100	35			
1140000	•	60°	40	24	25	L100	35			

